

- Suitable for all Jonesco mudguards with integral plastic slides (Radius > 510 mm, adjustable length 160 mm).
  - Easy to fit - slide the unit along the integral slide, secure, ready.
  - Ideal for Original Equipment Manufacturers.
  - Supplied ready assembled.
  - Very light – saves weight and fuel.
  - Made from polyamide – proven in various climates.
- Convient aux garde-boue de Jonesco (Rayon > 510 mm, possibilité d'ajustement: 160 mm) équipés de glissière plastique pré-montée.
  - Facile à monter - Faire coulisser la fixation ZPA dans la glissière intégrée.
  - Idéale pour les constructeurs.
  - Fournie pré-assemblée.
  - Très légère économisez du poids et du carburant.
  - Fabriquée en polyamide, résistante aux variations de température.
- für alle Jonesco Kotflügel mit integrierten Kunststoffführungen. (Radius > 510 mm), Verstellbereich 160 mm.
  - einfache Montage - die Halterung in die Führung schieben, sichern, fertig.
  - ideal für Erstausrüster.
  - wird vormontiert geliefert.
  - extrem leicht – gewicht- und kraftstoffsparend.
  - aus Polyamid – witterungs- und temperaturbeständig.

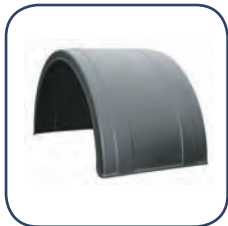

	Stay Ø Ø de Tube Tragrohr Ø	Units per Kit Unités par Kit Einheiten pro Kit
KITZPA34	34	4
KITZPA42	42	4
KITZPA48	48	4

**XGard****HighGard****J - MDPE****ValuGard**

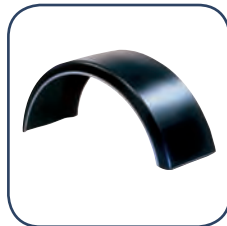
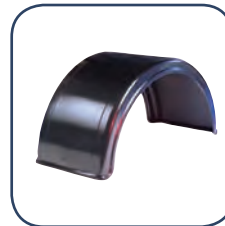
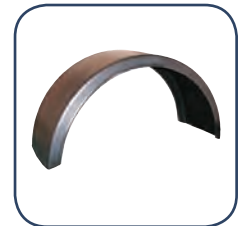
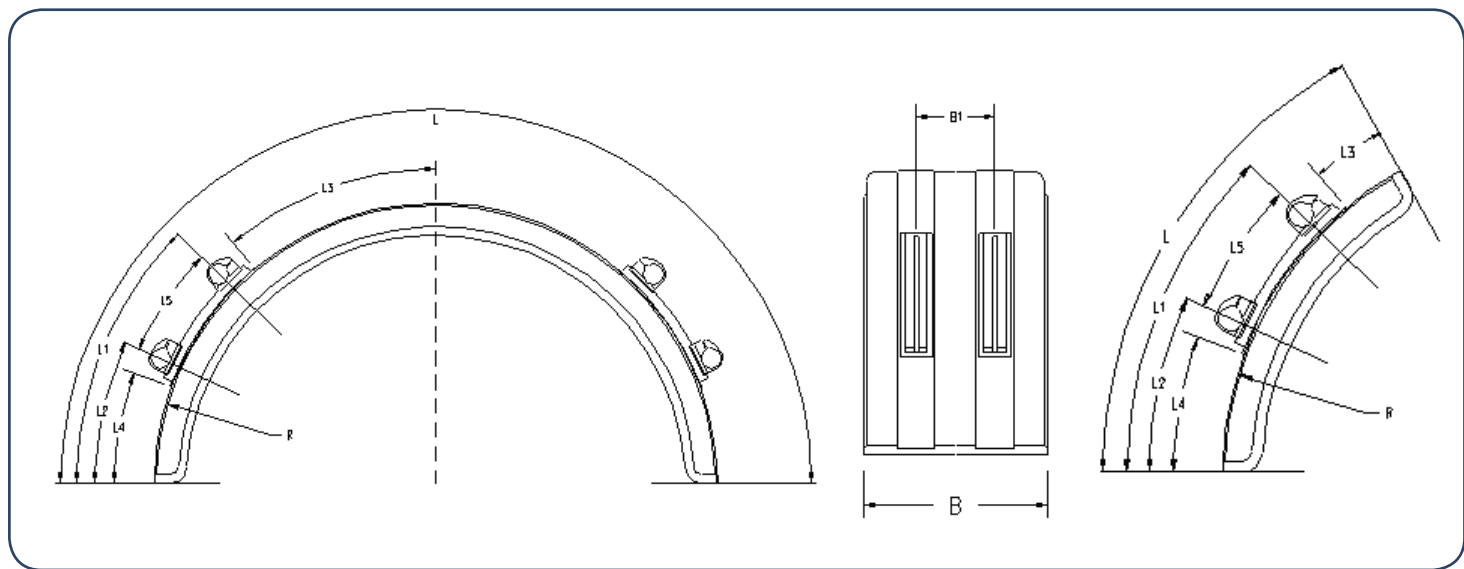

	(B) mm	(Bi) mm	(L) mm	(L1) mm	(L2) mm	(L3) mm	(L4) mm	(L5) mm	(B1) mm	(R) mm
KFXXHL26A	430	420	1900	595	360	285	310	235	200	635
KFXXHL26B	430	420	1990	615	380	310	330	235	200	635
KFXXHL30C	460	450	2050	625	390	330	340	235	200	640
KFXXHL31	460	450	1930	595	360	300	310	235	200	640
KFXXHL31A	460	450	1855	575	340	282	290	235	200	590
KFXXHL33	495	485	1600	515	280	215	230	235	200	510
KFXXHL38C	520	510	2050	625	390	330	340	235	300	660
KFXXHL39B	540	530	1610	515	280	220	230	235	300	510
KFXXHL40	560	550	1700	545	310	235	260	235	300	550
KFXXHL41	560	550	1930	595	360	300	310	235	300	635
KFXXHL43A	620	610	1930	595	360	300	310	235	400	640
KFXXHL43D	620	610	1790	565	330	260	280	235	400	550
KFXXHL43E	620	610	2085	635	400	340	350	235	400	640
KFXXHL45A	660	650	2090	635	400	340	350	235	400	650
KFXXHL45B	660	650	1900	595	360	285	310	235	400	650
KFXXHL47	680	670	2090	635	400	340	350	235	400	685
KFXXHL47B	680	670	1700	545	310	235	260	235	400	540
KFXXHL47D	680	670	1650	525	290	230	240	235	400	600
KFXXHL47F	680	670	2100	645	410	335	360	235	400	630
KFXXHL47G	680	670	1900	595	260	285	310	235	400	650
KFXXHL47M	680	670	2090	635	400	340	350	235	400	710

XX = 34, 42, 48 mm;  
 please specify stay Ø.  
 préciser le diamètre  
 de votre tube.  
 bitte Tragrohr Ø angeben.

	(B) mm	(Bi) mm	(L) mm	(L1) mm	(L2) mm	(L3) mm	(L4) mm	(L5) mm	(B1) mm	(R) mm
KFXXHLS26A	430	420	700	515	280	115	230	235	200	635
KFXXHLS26B	430	420	650	465	230	115	180	235	200	635
KFXXHLS26C	430	420	1000	715	480	215	430	235	200	635
KFXXHLS31	460	450	650	465	230	115	180	235	200	640
KFXXHLS31B	460	450	1000	715	480	215	430	235	200	640
KFXXHLS39B	540	530	650	465	230	115	180	235	300	510
KFXXHLS40	560	550	650	465	230	115	180	235	300	550
KFXXHLS43A	620	610	650	465	230	115	180	235	400	640
KFXXHLS45A	660	650	650	465	230	115	180	235	400	640

VERSTELLBARE HALTERUNGEN

SYSTEME DE FIXATION AJUSTABLE

ADJUSTABLE FIXINGS

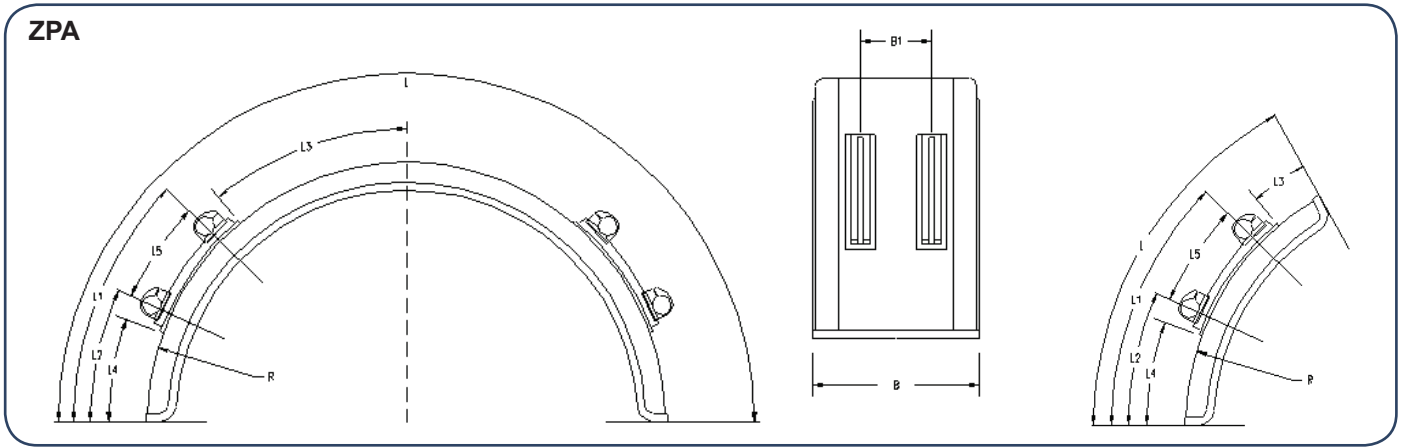

	(B) mm	(Bi) mm	(L) mm	(L1) mm	(L2) mm	(L3) mm	(L4) mm	(L5) mm	(B1) mm	(R) mm
KFXXJ12	300	285	1730	545	310	250	260	235	150	550
KFXXJ23	380	360	2140	655	420	345	370	235	200	670
KFXXJ24A	425	405	1930	595	360	300	310	235	200	580
KFXXJ24B	425	405	1930	595	360	300	310	235	200	640
KFXXJ24C	430	410	2070	635	400	330	350	235	200	620
KFXXJ25	400	380	2140	655	420	345	370	235	200	670
KFXXJ30C	475	455	2080	635	400	335	350	235	200	650
KFXXJ31	460	440	1900	595	360	285	310	235	200	640
KFXXJ33	505	485	1650	525	290	230	240	235	200	510
KFXXJ34	505	485	1790	565	330	260	280	235	200	530
KFXXJ35	505	485	1790	565	330	260	280	235	200	580
KFXXJ38C	530	510	2080	635	400	335	350	235	300	650
KFXXJ39	550	530	1930	595	360	300	310	235	300	615
KFXXJ39B	550	530	1680	535	300	235	250	235	300	510
KFXXJ41	580	560	1930	595	360	300	310	235	300	640
KFXXJ42	600	580	1930	595	360	300	310	235	300	640
KFXXJ43A	630	610	1930	595	360	300	310	235	400	640
KFXXJ43B	630	610	1830	575	340	270	290	235	400	550
KFXXJ44	630	610	2090	635	400	340	350	235	400	660
KFXXJ45A	670	650	2090	635	400	340	350	235	400	650
KFXXJ45B	660	640	1900	595	360	285	310	235	400	635
KFXXJ45C	660	640	1900	595	360	285	310	235	400	615
KFXXJ47	690	670	2090	635	400	340	350	235	400	690
KFXXJ47B	690	670	1700	545	310	235	260	235	400	535
KFXXJ48	730	710	2030	625	390	320	340	235	400	650

	(B) mm	(Bi) mm	(L) mm	(L1) mm	(L2) mm	(L3) mm	(L4) mm	(L5) mm	(B1) mm	(R) mm
KFXXJS11	270	250	600	415	180	115	130	235	150	660
KFXXJS19	350	330	720	535	300	115	250	235	200	650
KFXXJS21	400	380	700	515	280	115	230	235	200	670
KFXXJS23	400	380	850	585	350	195	300	235	200	670
KFXXJS26	400	380	1150	785	550	295	500	235	200	700
KFXXJS29	450	430	700	515	280	115	230	235	200	670
KFXXJS30A	475	455	660	475	240	115	190	235	200	690
KFXXJS31	470	450	1070	785	550	215	500	235	200	650
KFXXJS40	550	530	835	625	290	140	340	235	300	500
KFXXJS43A	630	610	640	455	220	115	170	235	400	640
KFXXJS45A	670	650	640	455	220	115	170	235	400	640
KFXXJS47	690	670	640	455	220	115	170	235	400	640

XGARD

	(B) mm	(Bi) mm	(L) mm	(L1) mm	(L2) mm	(L3) mm	(L4) mm	(L5) mm	(B1) mm	(R) mm
KFXXJX24	420	405	2150	655	420	350	370	235	180	655
KFXXJX26	425	410	1900	595	360	285	310	235	200	620
KFXXJX33	500	485	1600	525	290	230	240	235	200	510
KFXXJX43A	630	615	1930	595	360	300	310	235	400	640
KFXXJX45	670	655	2000	635	400	330	350	235	400	650

	(B) mm	(Bi) mm	(L) mm	(L1) mm	(L2) mm	(L3) mm	(L4) mm	(L5) mm	(B1) mm	(R) mm
KFXXJXS21	420	404	700	516	282	116	230	234	200	670
KFXXJXS45	670	654	700	516	282	116	230	234	400	670

XX = 34, 42, 48 mm;  
 please specify stay Ø.  
 préciser le diamètre  
 de votre tube.  
 bitte Tragrohr Ø angeben.